

SPECIFICATION

Flow rates	1 GPM (3.8 LPM) bottle fill 4 GPM (15.2 LPM) bucket fill
Back flow preventer	Flex-gap or Aire-Gap
Max Temperature	140° F (60° C)
Optimal Min Pressure	30 PSI (2 bar)
Optimal Max Pressure	60 PSI (4 bar)

MATERIAL SPECIFICATION

Cover	ABS
Flex-gap	Polypropylene
O-ring	EPDM & Viton
Water Valve	Acetal
Water Inlet	Brass

INSTALLATION

Mounting the unit

- (1) Choose a convenient location close to water supply and not more than 5' off floor.
- (2) Remove the cover of the unit as the mounting holes are behind the cover.
- (3) Hold the unit against the wall and mark keyholes (shown to the right) — use a level for marking holes.
- (4) Drill holes and install mounting anchors and screws (supplied).
- (5) Hang the unit and tighten screws. Always refer to hardware manufacturer's specifications for weight capacity and usage.
- (6) When reattaching the cover, be sure that the buttons line up properly with the tabs on the water valves and that the dials (if used) are properly aligned.

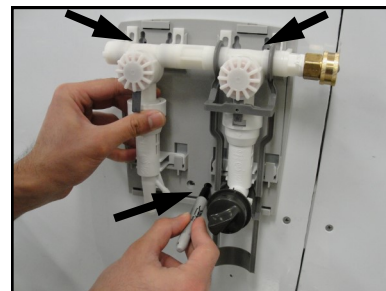

Connecting the water supply

This proportioner operates best with a flowing water pressure of 30 - 60 PSI. Fluctuating pressure can affect dilution ratios — use a water source that is not feeding other equipment whenever possible. Water temperature should be between 40°F and 140°F.

- (1) Attach male end of high pressure supply hose to inlet side of proportioner using a garden hose washer. Water inlet can be located on the left side if necessary (see optional water connections available, page 5).
- (2) Attach female connector on high pressure hose to water source.
- (3) Turn on water and check for possible leaks.

IMPORTANT NOTE:
If proportioner is connected to a janitor's sink with an atmospheric vacuum breaker, a special connection kit is required by A.S.S.E. specification 1055. Failure to use this kit, or equivalent connection means, will invalidate the A.S.S.E. and I.A.P.M.O. (UPC) certification. Specify P/N 7600187 when ordering the kit.



CAUTION: Wear protective clothing and eyewear when dispensing chemicals or other materials. Observe safety handling instructions (MSDS) of chemical mfrs.



CAUTION: When installing any equipment, ensure that all national and local safety and plumbing codes are met.

DIAL POSITION

The selector dial has 4 positions that correspond to the 4 chemical inlet ports (see figure to the right). Labels can be applied to the cover of the unit to identify where to point the dial for each particular chemical. When inserting metering tips, be sure to match up the correct tip for the chemical that will be used on each port.

OPERATION

Connecting the chemical supply

- (1) Locate chemical container(s) below the proportioner.
- (2) Insert the foot-valve end of the 3/8" vinyl tube into each container (use ceramic weight if necessary to sink tube to bottom).
- (3) For all ports, connect the inlet tube over the colored metering tip — secure with a plastic zip tie.

Installing bucket-fill or bottle fill tube (optional)

- (1) Connect the bucket or bottle fill tube with the flow restrictor (plastic insert) end closest to the venturi body.
- (2) Secure tube to venturi body with tie wraps provided.

Dispensing chemical-water mix

- (1) Select the desired product with the selector knob (for dial operated units).
- (2) Press the button on the front cover—release button when container is full.
- (3) If desired, the button can be “locked” in the ON position for filling large containers such as mop buckets or floor scrubbers. Simply push the latch into the button when pressed in. To release, push latch away from button.

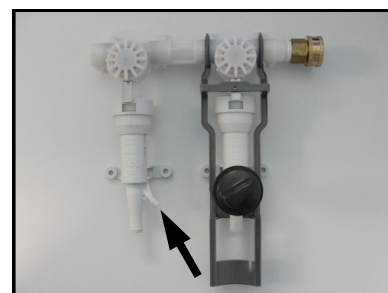
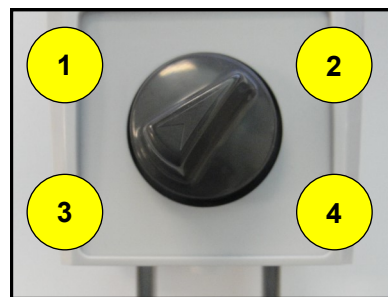

CHOOSING THE FLOW RATE

FLEX-GAP VENTURI

For the Flex-Gap systems, the flow rate is controlled by a venturi insert located inside bottom of the Flex-gap housing.

WHITE Venturi insert (2200106) = 1 GPM
BLACK Venturi insert (2200105) = 4 GPM

To change the venturi insert.

- (1) Remove the cover by gently snapping it away from the unit.
- (2) Disconnect tubing from Flex-Gap housing.
- (3) Twist the Flex-Gap housing counter-clockwise to remove it from the water valve body.
- (4) Push out existing venturi tube by inserting a pen up through the bottom of the Flex-Gap housing (note the order of the parts as they are removed from the flex-gap/venturi housing). **See Figure 1**
- (5) Insert the new venturi insert (for the desired flow rate) into the Flex-Gap housing, ensuring that it seats firmly. Place the flex-gap parts in the order removed from the previous step.
- (6) Twist the Flex-Gap housing clockwise to reattach it to the water valve.

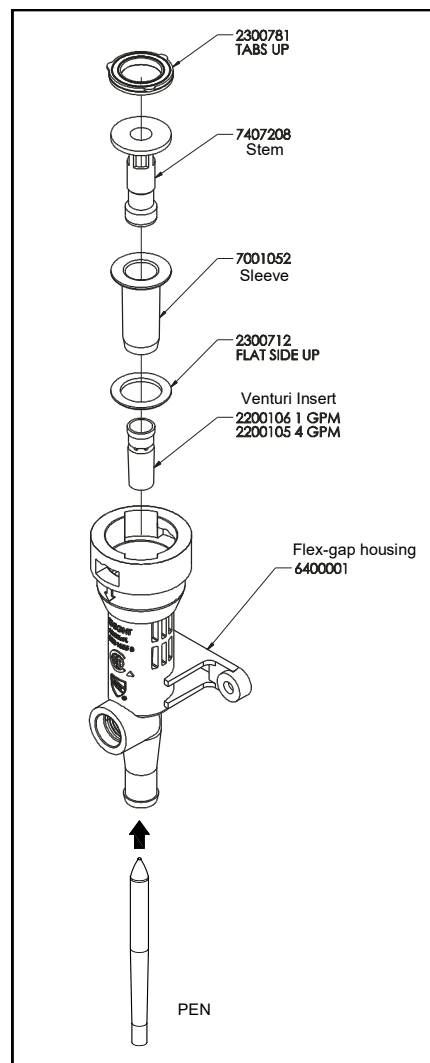

Figure 1 (Flex-Gap Assembly)

AIRE-GAP VENTURI

For Aire-Gap venturi systems, the flow rate is controlled by a nozzle, deflector plate, and venturi insert. These internal parts are color coded to identify their GPM rating: Aire-Gap Nozzle: LIGHT GREY = 1 GPM / LIGHT BLUE = 4 GPM Splash Deflector & Venturi tube: WHITE = 1 GPM / BLACK = 4 GPM. To change the Aire-Gap venturi:

- (1) Remove the cover by gently snapping it away from the unit. Disconnect tubing from Aire-gap housing.
- (2) Twist and disconnect Aire-Gap housing counter-clockwise to remove water valve body.
- (3) Remove existing nozzle, deflector plate, and venturi tube by disassembling the Aire-Gap assembly — See Figure 2.
- (4) Reassemble the Aire-Gap using new nozzle, splash deflector, and venturi tube (for the desired flow rate). To avoid leakage, install the rubber washer with the ribs facing upwards.
- (5) Put Aire-Gap assembly back in place in the order that parts were removed.
- (6) Twist and reconnect Aire-Gap assembly back onto the water valve body.

CHOOSING DILUTION RATES

METERING TIP SELECTION

The dilution chart for Flex-Gap and Aire-Gap venturi are the same for both 1 GPM and 4 GPM flow rates. For each valve in the system, install appropriate metering tip from the chart below. Be sure the metering tip is threaded in hand-tight only.

CALIBRATING ACTUAL PRODUCT RATIOS

To easily calculate the ounces per gallon for a specific product:

- (1) Fill a graduated cylinder, or bottle (that has ounce markings) with product.
- (2) Install metering tip closest to the desired ounces per gallon — see dilution charts.
- (3) Drop chemical pick-up tube into the container holding the product.
- (4) Activate valve until chemical line is primed up to the metering tip.
- (5) Note how many ounces (of product) are in the container.
- (6) Activate valve again and fill a one gallon container with water/product mix.
- (7) Note how many ounces (of product) were used.
- (8) You now have determined actual ounces per gallon for this product.

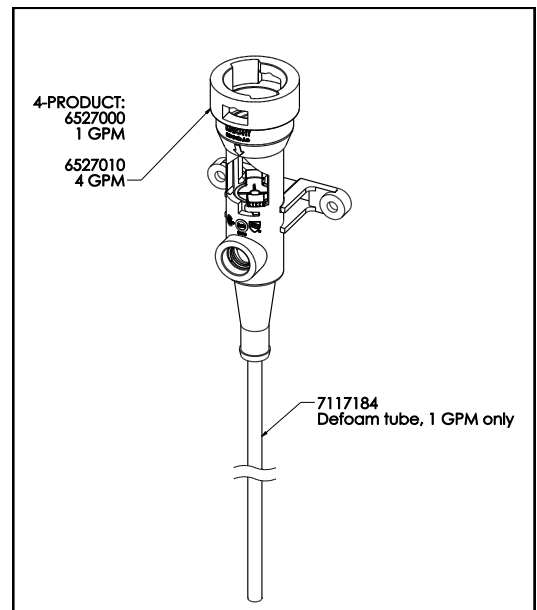

Figure 2 (Aire-Gap Assembly)

METERING TIP CHART (Flex-Gap & Aire-Gap Venturi)				
TIP COLOR	1 GPM		4 GPM	
	OZ/GAL	RATIO	OZ/GAL	RATIO
NO INSERT				
WHITE	30.00	4.3:1	14.00	9.1:1
YELLOW	29.00	4.4:1	13.00	9.8:1
PINK	27.00	4.7:1	11.00	11.6:1
GREEN	24.00	5.3:1	9.00	14.2:1
BLACK	20.00	6.4:1	7.00	18.3:1
BROWN	14.00	9.1:1	5.00	25.6:1
GRAY	10.00	12.8:1	4.00	32.0:1
BLUE	8.00	16.0:1	3.00	42.7:1
RED	6.00	21.3:1	2.00	64.0:1
PEACH	5.00	25.6:1	1.50	85.3:1
LT BLUE	4.00	32.0:1	1.25	102.4:1
PURPLE	3.00	42.7:1	1.00	128.0:1
LT GREEN	2.00	64.0:1	0.75	170.7:1
ORANGE	1.00	128.0:1	0.50	256.0:1
LT BROWN	0.50	256.0:1	0.25	512.0:1

This chart is based upon the chemical viscosity of water (CPS = 1.0) and should only be used as a guide. Actual ratios and flow rates may vary due to product viscosity, flow pressure, and tubing distance.

TORTUOUS PATH METERING DEVICE (TPMD)

Many sink sanitizers and concentrated cleaning products require dilution rates that exceed 250 to 1. For these products, the TPMD was developed to meter precise amounts of chemical to water without plugging, and with unparalleled accuracy. Dilution rates range from 250:1 to 1500:1 with the Flex Gap or Aire Gap backflow preventers. The following table will guide your selection of the TPMD that suits your needs. Tortuous paths metering devices are optional items.

DILUTION	DYNAMIC WATER PRESSURE		
	30 PSI	40 PSI	50 PSI
1 GPM			
512:1	P/N 2201221-35	P/N 2201221-30	P/N 2201221-25
4 GPM			
512:1	P/N 2201221-05	P/N 2201221-05	P/N 2201221-05
750:1	P/N 2201221-10	P/N 2201221-10	P/N 2201221-10
935:1	P/N 2201221-15	P/N 2201221-15	P/N 2201221-15
1400:1	P/N 2201221-25	P/N 2201221-25	P/N 2201221-25

Note: Mixing Ratios should be used for reference only. Ratios and flow rate will vary depending on water pressure, chemical viscosity, and length of chemical lines.

CONNECTING MULTIPLE UNITS

- Multiple units can be connected side by side using the quick connector (7366049) for any configuration that is required. See **Figure 3**
- Water inlet connection can be relocated from right to left side if necessary by following the steps below.
 - (1) Remove the brass inlet fitting from the right side by turning it counter-clockwise (Figure 4).
 - (2) Remove the plastic plug from the left side by turning it counter-clockwise.
 - (3) Insert the brass inlet fitting into the left side by turning it clockwise until hand-tight and the flats are aligned.
 - (4) Insert the plastic plug into the right side by turning it clockwise until hand-tight and the flats are aligned.

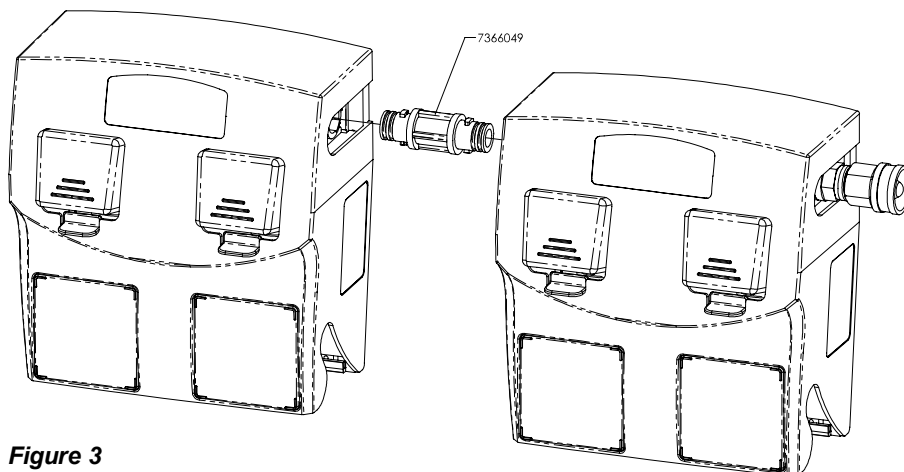

Figure 3

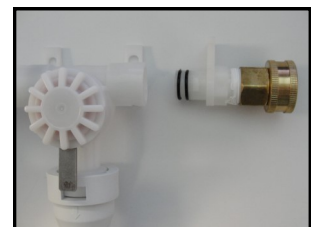

Figure 4

SAFETY AND SERVICING TIPS

- Avoid direct contact with chemicals — handle containers with caution. To avoid spillage, be careful not to tip containers.
- Insert chemical suction line into container so that footvalve and ceramic weight sink to the bottom.
- If valve fails to draw chemical, check the metering tip and footvalve for blockage — soak in warm water to clear.

TROUBLESHOOTING

1. Proportioner will not draw chemical:
 - A. Check metering tip for obstruction.
 - B. Check water pressure for 30 – 60 PSI.
 - C. Check or change footvalve.
2. Proportioner leaks at joints:
 - A. Ensure that there are two o-rings in place and in good condition on each end of connector.
3. Mixed chemical concentration is too weak:
 - A. Check water pressure for a minimum of 25 PSI of flow pressure.
 - B. Change metering tip to a higher dilution ratio.
4. Supply line loses chemical prime:
 - A. Check or change foot valve.
5. Water leaks at cap on valve assembly:
 - A. Check that cap is fully turned clock-wise and tight.
 - B. Check for debris or damage to valve tab assembly
 - C. Excessive water pressure. Use Regulator.
6. Button activator will not activate valve:
 - A. The cover is loose or damaged, snap on cover or replace the cover.
 - B. Adjust calibration screw until full flow is achieved. **See Figure 5**
7. Dial 4 will not draw chemical:
 - A. Check condition of o-ring on dial selector knob. **See Figure 6**
 - B. Ensure Dial “Clicks” to selected product.
8. Low water flow:
 - A. Check that diaphragm cover is firmly attached.
 - B. Check for sediment in screen washer or valve body.
 - C. Check water pressure.

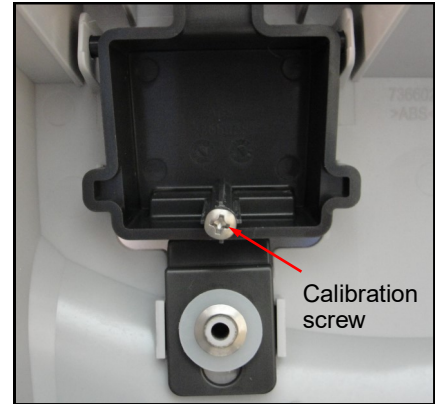

Figure 5

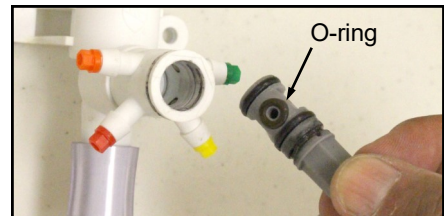

Figure 6

ACCESSORY KIT PARTS (NOT SHOWN)

Note: Quantities and variations of the items will vary depending the system ordered.

Part Number	DESCRIPTION
0300519	Ceramic Tube Weight
0901220	Manual
0300121	3.5" Cable Ties
2201200	Metering tip kit with chart
2201225	Umbrella Foot Valve
7025842	Pick-up Tube, T-38V Vinyl 1/4" ID x 3/8" OD 6 ft.
7026905	6' Chemical Discharge Tube w/ restrictor, (Flex-gap bucket fill hose)
7026905-1	6" Chemical Discharge Tube w/ restrictor, (Flex-gap bottle fill hose)
1202012	Chemical Labels
7600121	Mounting Kit w/ #10 Screws and anchors - 2 ea

OPTIONAL ITEMS

Part Number	DESCRIPTION
6400006	Metering tip wrench
7366041-25	Quick Water Connection, Hose Swivel-US, 25 each
7366040-25	Quick Water Connection, Hose Swivel-UK, 25 each
0600873-10	Quick Connect, 3/8" John Guest Elbow, 10 each
0600874-10	Quick Connect, 3/8: Compression, 10 each
7366035	Quick Connect, 1/2" barb, 25 each
7366049	Quick Connect Valve Connector

SINGLE ENGINE PARTS DIAGRAM

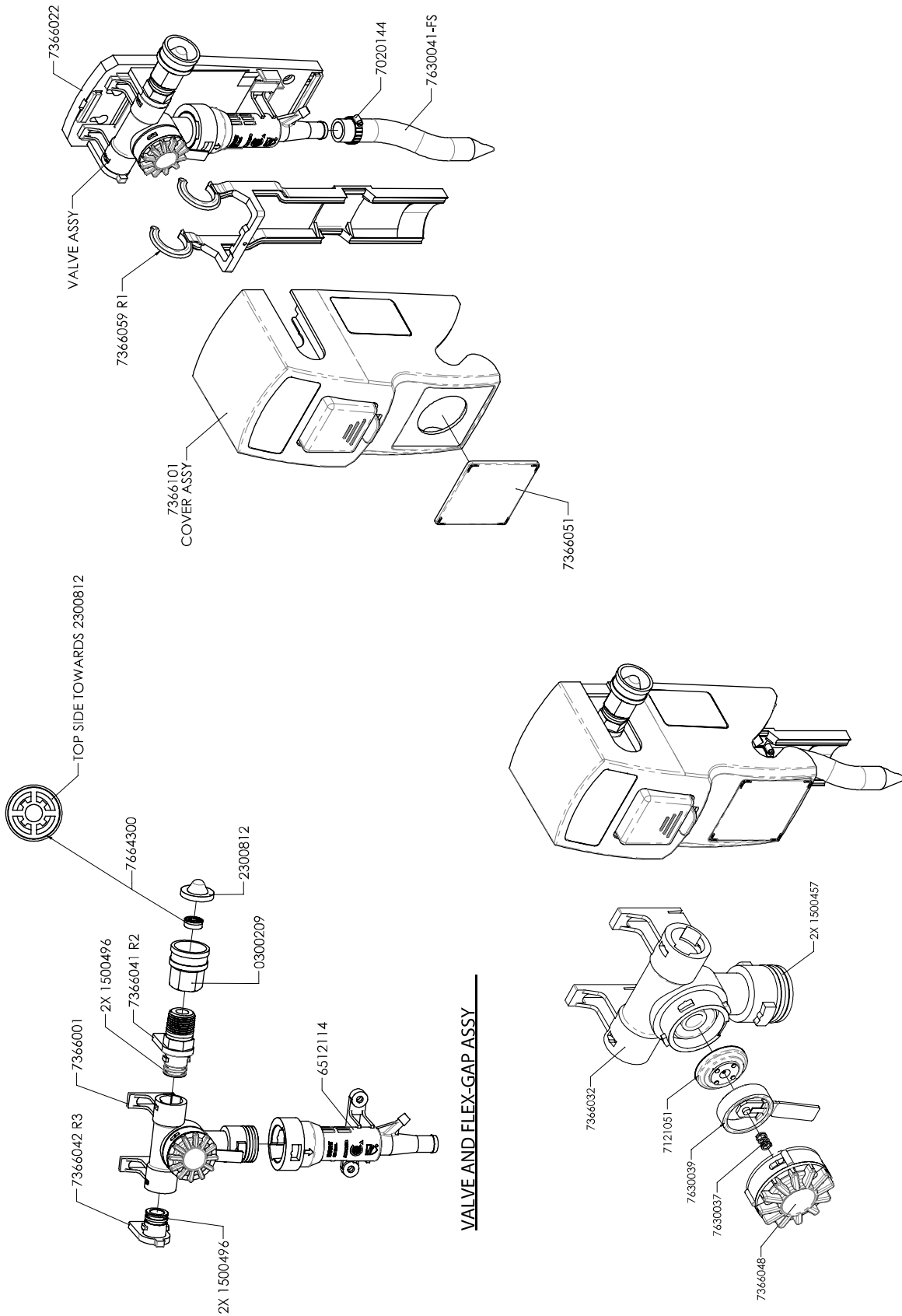

DUAL ENGINE PARTS DIAGRAM

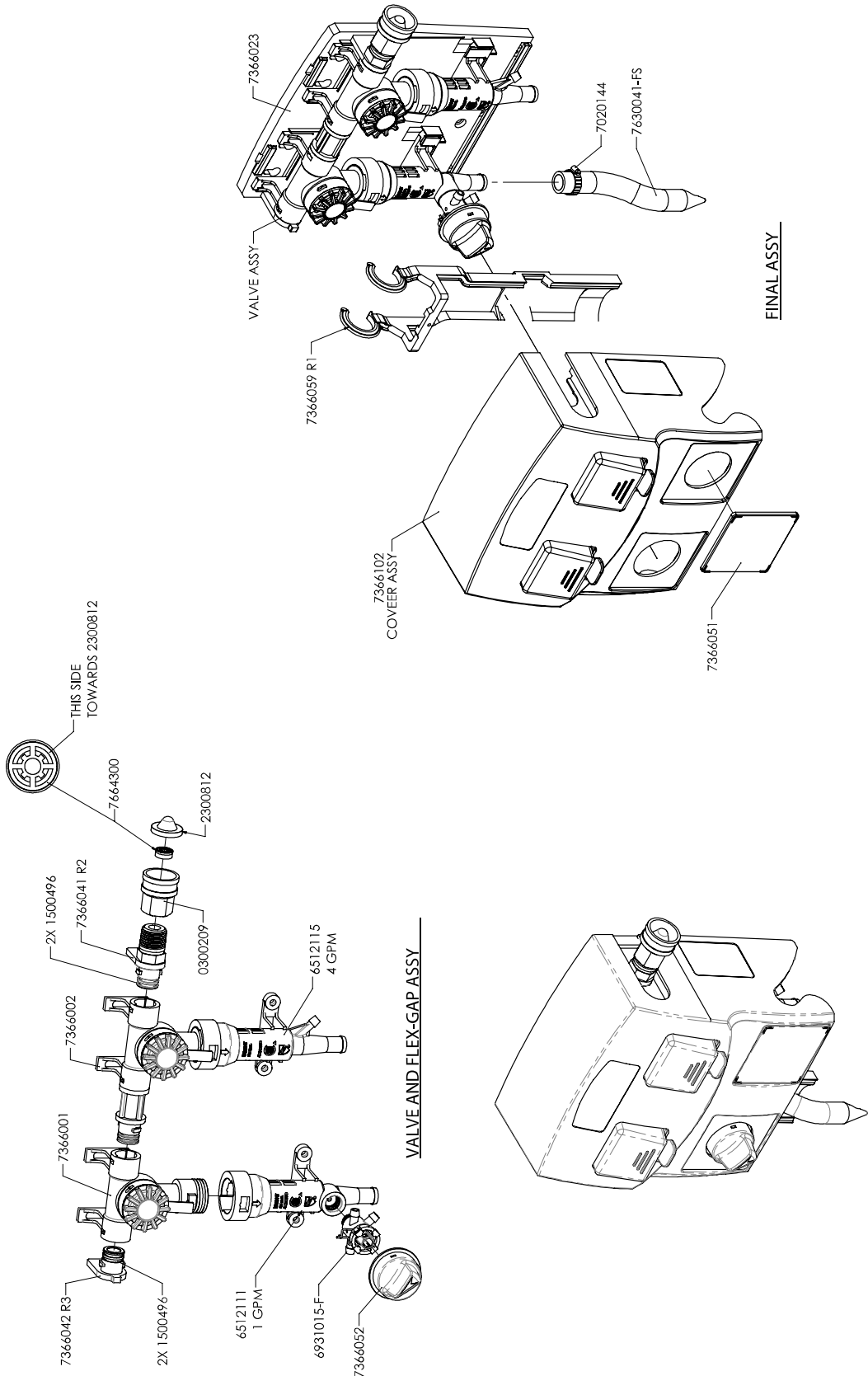

TRIPLE ENGINE PARTS DIAGRAM

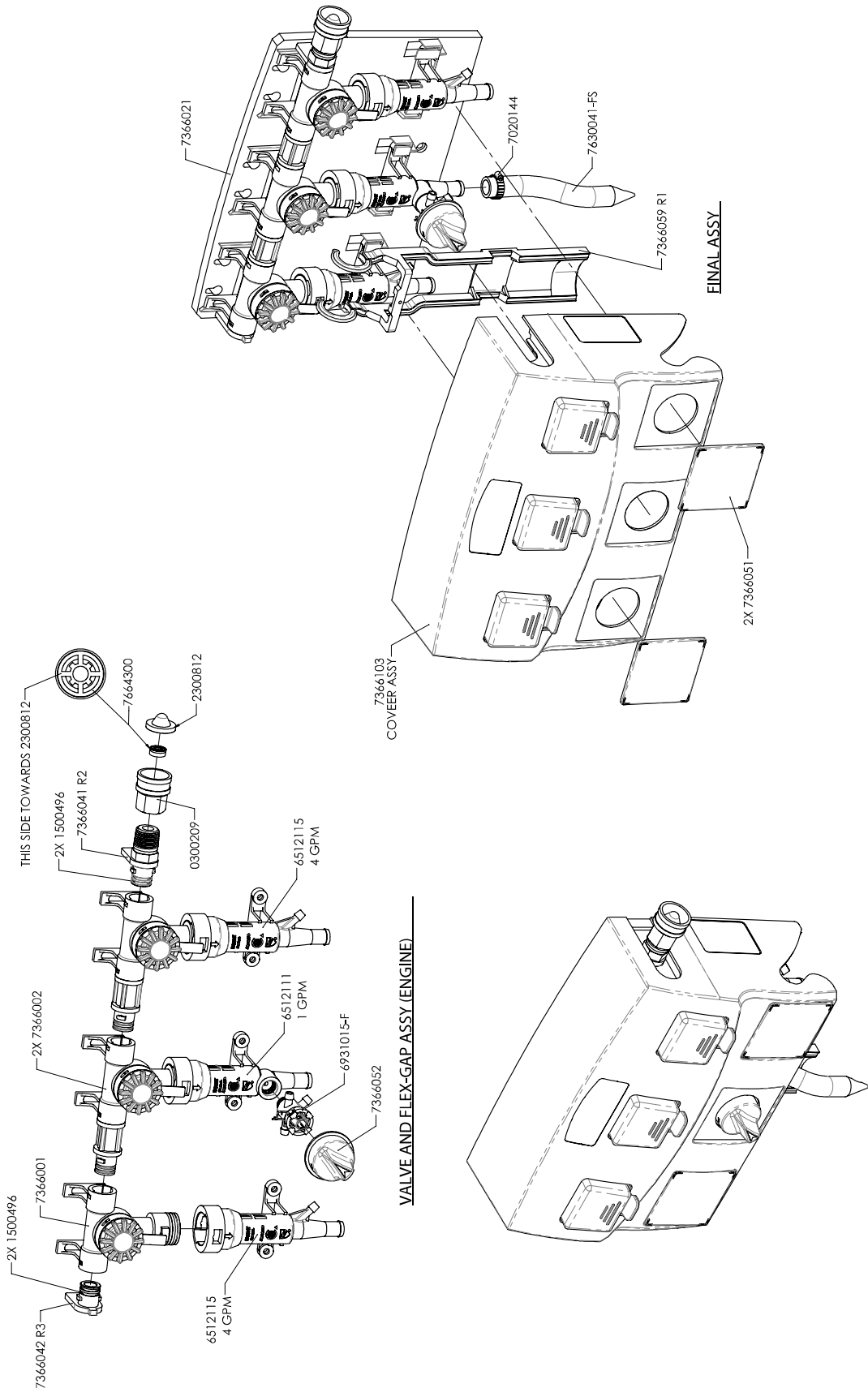

FLEX-GAP ANNUAL CLEANING AND TEST PROCEDURES FOR UNITS INSTALLED IN CANADA

Each year, your chemical dispenser must be cleaned and its backflow prevention performance verified. As this device is an end-of-line device (versus an in-line device) and evidence of effective backflow prevention is determined visually, a two-minute pressure test is not necessary.

If the Flex-Gap device cannot readily be seen during the test procedure, the housing of the chemical dispensing unit must be removed during testing. Apply the appropriate test procedure below as applicable for your chemical dispensing unit.

4 GPM VENTURIS

1. Fill discharge hose with water by opening the valve.
2. When water begins to exit the discharge hose turn off the water and raise the end of the hose above the Flex-Gap.
3. Observe that water is exiting the Flex-Gap.
4. If the water is exiting the Flex-Gap it has passed the test.
5. If the water is not exiting from the Flex-Gap, replace the Flex-Gap sleeve as per the instruction manual and re-test.
6. If the water is not exiting from the Flex-Gap after replacing the sleeve and re-testing, replace the complete Flex-Gap assembly and re-test.
7. If the water is not exiting from the Flex-Gap after replacing the Flex-Gap assembly, disconnect the water supply and replace the complete unit.

1 GPM VENTURIS

1. Remove the Fill Tube Spout and replace with a 4-foot length of 1/2" ID hose.
2. Fill the discharge hose with water by opening the valve.
3. When water begins to exit the discharge hose, turn off the water and raise the end of the hose above the Flex-Gap.
4. Observe that water is exiting the Flex-Gap.
5. If the water is exiting the Flex-Gap, it has passed the test.
6. If the water is not exiting from the Flex-Gap, replace the Flex-Gap sleeve and re-test.
7. If the water is not exiting from the Flex-Gap after replacing the sleeve and re-testing, replace the complete Flex-Gap assembly and re-test.
8. If the water is not exiting from the Flex-Gap after replacing the Flex-Gap assembly, disconnect the water supply and replace the complete unit.

NOTES

NOTES

DISCLAIMER

Knight LLC does not accept responsibility for the mishandling, misuse, or non-performance of the described items when used for purposes other than those specified in the instructions. For hazardous materials information consult label, MSDS, or Knight LLC. Knight products are not for use in potentially explosive environments. Any use of our equipment in such an environment is at the risk of the user, Knight does not accept any liability in such circumstances.

WARRANTY

All Knight controls and pump systems are warranted against defects in material and workmanship for a period of ONE year. All electronic control boards have a TWO year warranty. Warranty applies only to the replacement or repair of such parts when returned to factory with a Knight Return Authorization (KRA) number, freight prepaid, and found to be defective upon factory authorized inspection. Bearings and pump seals or rubber and synthetic rubber parts such as "O" rings, diaphragms, squeeze tubing, and gaskets are considered expendable and are not covered under warranty. Warranty does not cover liability resulting from performance of this equipment nor the labor to replace this equipment. Product abuse or misuse voids warranty.

FOOTNOTE

The information and specifications included in this publication were in effect at the time of approval for printing. Knight LLC reserves the right, however, to discontinue or change specifications or design at any time without notice and without incurring any obligation whatsoever.

KNIGHT LLC (www.knightequip.com)

Knight Headquarters
Tel: 949.595.4800
Fax: 949.595.4801

USA Toll Free
Tel: 800.854.3764

Knight Canada
Tel: 905.542.2333
Fax: 905.542.1536